

MINUTEMAN VERTICAL BOILER FEED UNITS FOR UP TO 14,000 EDR SYSTEMS



MINUTEMAN VERTICAL BOILER FEED units establish the standard for value and quality. Our boiler feed units are competitively priced but also offer long term cost savings by virtue of the fact that we build our units with industry standard electric motors. By building our pumps with high quality industry standard electric motors our customers can easily make repairs using standard off the shelf components. The result is significant cost savings over the life of the unit.

Units are floor mounted vertical style to minimize floor space and engineered to efficiently pump water up to temperatures of 200°F for systems up to 16,000 square foot EDR and discharge pressures up to 20 PSIG. A mechanical make-up water valve is standard with stainless steel float and rubber fitted sealing face. Units are available in either simplex or duplex configurations with 3500 RPM, single-phase, ODP industry standard motors. Motors and mechanical seals are rated for temperatures up to 250°F. Higher temperature units are available upon request.

FEATURES

Industry Standard Motor

- Universal availability lowers cost and down time.

Bronze Impeller and Wear Ring

- Superior corrosion and wear resistance increases pump life.

Centrifugal Technology

- Allows pump to operate at low suction head levels.

TECHNICAL SPECIFICATIONS

- Industry standard ODP 3500 RPM motors factory wired for 115 or 230/1/60 with built-in thermal overload protection. Bronze impeller and wear ring for extended pump life.
 - Welded 3/16" thick steel receiver available in sizes 30 to 100 gallons. All simplex units have blank pad to convert to a duplex style if desired.
 - Gauge glass assembly for viewing water level.
- Pumps are designed to efficiently pump condensate up to 200°F and mechanical seals will withstand 250°F.

HOW TO SELECT AND ORDER CONDESATE UNITS

- Select unit size based on pump GPM, PSIG, and receiver size.
- First determine GPM. GPM is determined by multiplying the evaporation rate of the boiler by 1.5 to 2.0. The boiler evaporation rate is 0.69 gallons per minute for each boiler horsepower.
- Determine receiver size. Receiver size in general should be one gallon per one boiler horsepower including all boilers to be fed by the same feed unit.
- Generally low pressure boilers run at 0.5 to 15 PSIG so a 20 PSIG pump will be adequate. If unit is used as a surge tank, pumps should run continuously.
- Specify catalog number when placing order.

Boiler HP	System Sq. Ft. EDR	Receiver Size	Pump GPM	Pump PSIG	Pump Type	Pump HP	# of Pumps	Pump Discharge Size	Catalog Number
20	2788	30	4	20	VM33101	1/3	1	3/4	MMV-030-1
20	2788	30	4	20	VM33101	1/3	2	3/4	MMV-030-2
40	5576	50	6	20	VM33101	1/3	1	3/4	MMV-050-1
40	5576	50	6	20	VM33101	1/3	2	3/4	MMV-050-2
100	13940	100	14	20	VM33101	1/3	1	3/4	MMV-100-1
100	13940	100	14	20	VM33101	1/3	2	3/4	MMV-100-2

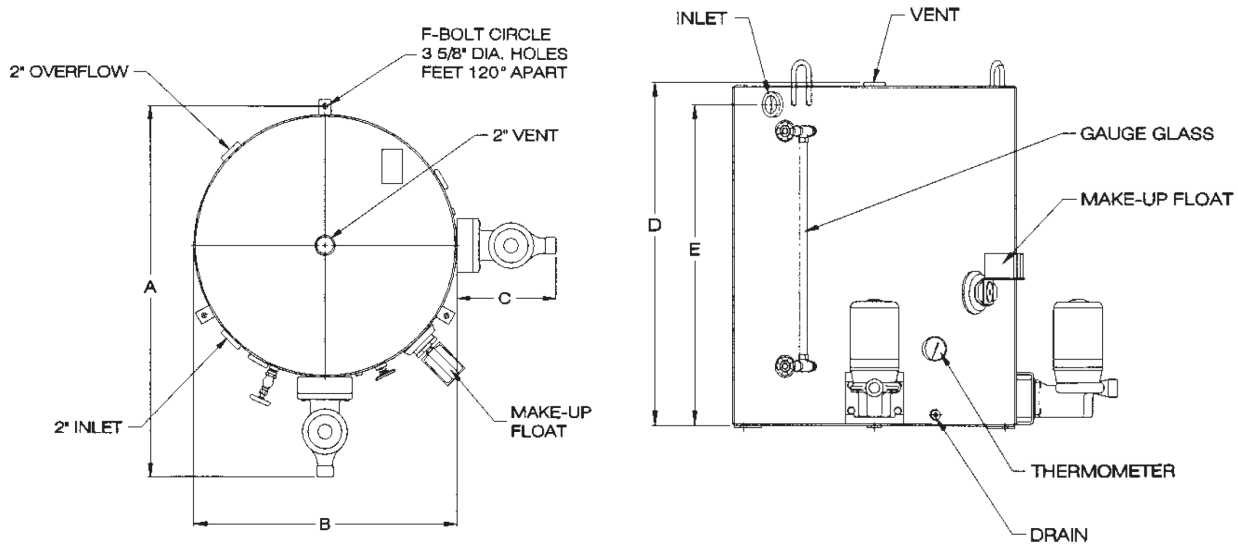

Receiver Size	A	B	C	D	E	F	Inlet	Overflow	Vent	Net Storage Gal.
30	32-1/2	19-1/2	13	25	22-1/2	20-7/8	2"	2"	2"	20
50	32-1/2	19-1/2	13	37	34-3/4	20-7/8	2"	2"	2"	33
100	43-1/2	30-1/2	13	37	34-3/4	32	2"	2"	2"	66